

# *Rogue EM 180*

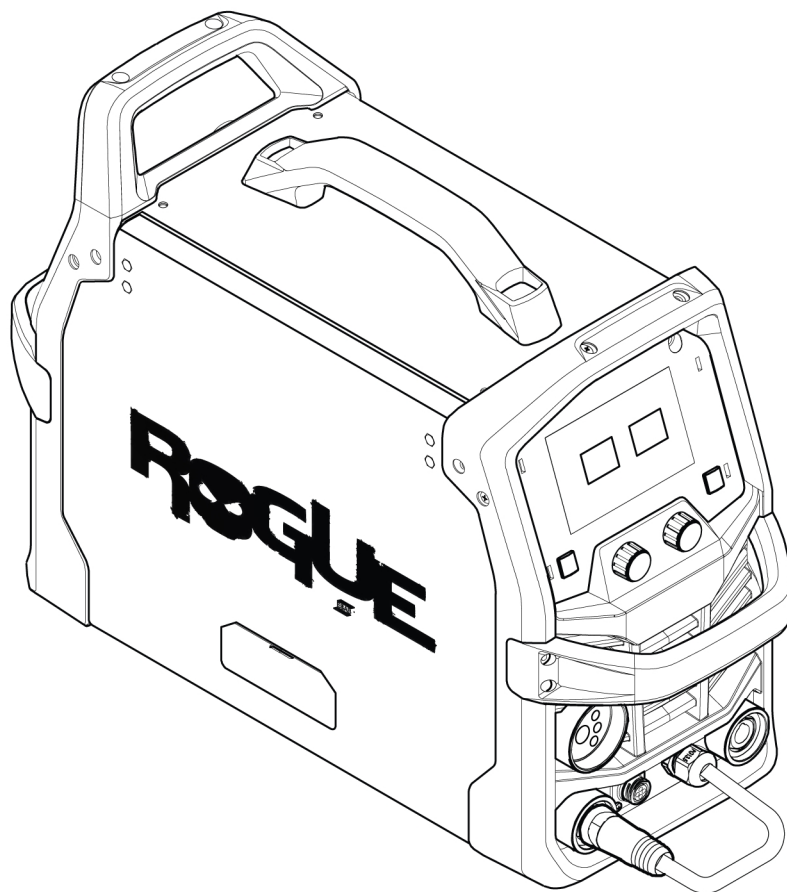

## Instruction manual



## EU DECLARATION OF CONFORMITY

**According to:**

The Low Voltage Directive 2014/35/EU;      The EMC Directive 2014/30/EU;  
The RoHS Directive 2011/65/EU;              The Ecodesign Directive 2009/125/EC

**Type of equipment**

Arc welding power source

**Type designation**

Rogue EM 180                                      from serial number HA438 YY XX XXXX  
X and Y represents digits, 0 to 9 in the serial number, where YY indicates year of production.

**Brand name or trademark**

ESAB

**Manufacturer or his authorised representative established within the EEA**

ESAB AB  
Lindholmsallén 9, Box 8004, SE-402 77 Göteborg, Sweden  
Phone: +46 31 50 90 00, www.esab.com

**The following EN standards and regulations in force within the EEA has been used in the design:**

EN IEC 60974-1:2018/A1:2019	Arc Welding Equipment - Part 1: Welding power sources
EN IEC 60974-5:2019	Arc welding equipment - Part 5: Wire feeders
EU reg. no. 2019/1784	Ecodesign requirements for welding equipment pursuant to Directive 2009/125/EC
EN 60974-10:2014	Arc Welding Equipment - Part 10: Electromagnetic compatibility (EMC) requirements

**Additional Information:**

Restrictive use, Class A equipment, intended for use in locations other than residential.

**By signing this document, the undersigned declares as manufacturer, or the manufacturer's authorised representative established within the EEA, that the equipment in question complies with the safety and environmental requirements stated above.**

**Place/Date**

Gothenburg  
2024-08-29

**Signature**

Peter Burchfield  
General Manager, Equipment Solutions



TABLE OF CONTENTS

<b>1</b>	<b>SAFETY</b> .....	<b>4</b>
1.1	Meaning of symbols .....	4
1.2	Safety precautions .....	4
<b>2</b>	<b>INTRODUCTION</b> .....	<b>7</b>
2.1	Equipment .....	7
<b>3</b>	<b>TECHNICAL DATA</b> .....	<b>8</b>
<b>4</b>	<b>INSTALLATION</b> .....	<b>10</b>
4.1	Location .....	10
4.2	Lifting instructions .....	10
4.3	Mains supply .....	11
4.4	Recommended fuse and cable sizes .....	12
<b>5</b>	<b>OPERATION</b> .....	<b>13</b>
5.1	Connections .....	14
5.2	Cable connection - Weld, return and polarity change over .....	14
5.3	Drive system diagram .....	15
5.4	Attaching MXL 201 with central adapter .....	15
5.5	Inserting and replacing wire .....	17
5.5.1	Welding with aluminium wire .....	18
5.5.2	Installing 5 kg (200 mm spool) .....	18
5.5.3	Installing 1 kg (100 mm spool) .....	19
5.6	Setting the wire feed pressure .....	19
5.7	Changing the feed/pressure rollers .....	20
5.8	Shielding gas .....	20
5.9	Duty cycle .....	21
<b>6</b>	<b>USER INTERFACE</b> .....	<b>22</b>
6.1	External control panel .....	22
6.2	Weld variables .....	22
6.3	Arc dynamics and trigger selection .....	23
6.4	Synergic control panel .....	24
6.5	Wire inching and gas purge button .....	24
6.6	Icon reference guide .....	25
<b>7</b>	<b>MAINTENANCE</b> .....	<b>26</b>
7.1	Routine maintenance .....	26
7.2	Power source and wire feeder maintenance .....	28
7.3	Torch and liner maintenance .....	29
<b>8</b>	<b>ERROR CODES</b> .....	<b>30</b>
8.1	Error code descriptions .....	30
<b>9</b>	<b>TROUBLESHOOTING</b> .....	<b>31</b>
<b>10</b>	<b>ORDERING SPARE PARTS</b> .....	<b>32</b>
	<b>WIRING DIAGRAM</b> .....	<b>33</b>
	<b>ORDERING NUMBERS</b> .....	<b>35</b>
	<b>WEAR PARTS</b> .....	<b>36</b>
	<b>ACCESSORIES</b> .....	<b>37</b>

---

# 1 SAFETY

---

## 1.1 Meaning of symbols

As used throughout this manual: Means Attention! Be Alert!

**DANGER!**

Means immediate hazards which, if not avoided, will result in immediate, serious personal injury or loss of life.

**WARNING!**

Means potential hazards which could result in personal injury or loss of life.

**CAUTION!**

Means hazards which could result in minor personal injury.

**WARNING!**

Before use, read and understand the instruction manual and follow all labels, employer's safety practices and Safety Data Sheets (SDSs).



## 1.2 Safety precautions

Users of ESAB equipment have the ultimate responsibility for ensuring that anyone who works on or near the equipment observes all the relevant safety precautions. Safety precautions must meet the requirements that apply to this type of equipment. The following recommendations should be observed in addition to the standard regulations that apply to the workplace.

All work must be carried out by trained personnel well-acquainted with the operation of the equipment. Incorrect operation of the equipment may lead to hazardous situations which can result in injury to the operator and damage to the equipment.

1. Anyone who uses the equipment must be familiar with:
  - its operation
  - location of emergency stops
  - its function
  - relevant safety precautions
  - welding and cutting or other applicable operation of the equipment
2. The operator must ensure that:
  - no unauthorised person is stationed within the working area of the equipment when it is started up
  - no-one is unprotected when the arc is struck or work is started with the equipment
3. The workplace must:
  - be suitable for the purpose
  - be free from drafts
4. Personal safety equipment:
  - always wear recommended personal safety equipment, such as safety glasses, flame-proof clothing, safety gloves
  - do not wear loose-fitting items, such as scarves, bracelets, rings, etc., which could become trapped or cause burns

5. General precautions:

- make sure the return cable is connected securely
- work on high voltage equipment **may only be carried out by a qualified electrician**
- appropriate fire extinguishing equipment must be clearly marked and close at hand
- lubrication and maintenance must **not** be carried out on the equipment during operation

**If equipped with ESAB cooler**

Use ESAB approved coolant only. Non-approved coolant might damage the equipment and jeopardize product safety. In case of such damage, all warranty undertakings from ESAB cease to apply.

For ordering information, see the "ACCESSORIES" chapter in the instruction manual.



**WARNING!**

Arc welding and cutting can be injurious to yourself and others. Take precautions when welding and cutting.



**ELECTRIC SHOCK - Can kill**

- Install and ground the unit in accordance with instruction manual.
- Do not touch live electrical parts or electrodes with bare skin, wet gloves or wet clothing.
- Insulate yourself from work and ground.
- Ensure your working position is safe.



**ELECTRIC AND MAGNETIC FIELDS - Can be dangerous to health**

- Welders having pacemakers should consult their physician before welding. EMF may interfere with some pacemakers.
- Exposure to EMF may have other health effects which are unknown.
- Welders should use the following procedures to minimize exposure to EMF:
  - Route the electrode and work cables together on the same side of your body. Secure them with tape when possible. Do not place your body between the torch and work cables. Never coil the torch or work cable around your body. Keep welding power source and cables as far away from your body as possible.
  - Connect the work cable to the workpiece as close as possible to the area being welded.



**FUMES AND GASES - Can be dangerous to health**

- Keep your head out of the fumes.
- Use ventilation, extraction at the arc, or both, to take fumes and gases away from your breathing zone and the general area.



**ARC RAYS - Can injure eyes and burn skin**

- Protect your eyes and body. Use the correct welding screen and filter lens and wear protective clothing.
- Protect bystanders with suitable screens or curtains.



**NOISE - Excessive noise can damage hearing**

Protect your ears. Use earmuffs or other hearing protection.



**MOVING PARTS - Can cause injuries**

- Keep all doors, panels, guards, and covers closed and securely in place.
- Have only qualified people remove covers for maintenance and troubleshooting as necessary.



- Keep hands, hair, loose clothing and tools away from moving parts.
- Reinstall panels or covers and close doors when service is finished and before starting the unit.



**FIRE HAZARD**

- Sparks (spatter) can cause fire. Make sure that there are no inflammable materials nearby.
- Do not use on closed containers.



**HOT SURFACE - Parts can burn**

- Do not touch parts bare handed.
- Allow cooling period before working on equipment.
- To handle hot parts, use proper tools and/or insulated welding gloves to prevent burns.



**CAUTION!**

This product is solely intended for arc welding.



**CAUTION!**

Class A equipment is not intended for use in residential locations where the electrical power is provided by the public low-voltage supply system. There may be potential difficulties in ensuring electromagnetic compatibility of class A equipment in those locations, due to conducted as well as radiated disturbances.

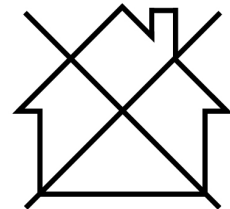

**NOTE!**

**Dispose of electronic equipment at the recycling facility!**

In observance of European Directive 2012/19/EC on Waste Electrical and Electronic Equipment and its implementation in accordance with national law, electrical and/or electronic equipment that has reached the end of its life must be disposed of at a recycling facility.

As the person responsible for the equipment, it is your responsibility to obtain information on approved collection stations.

For further information contact the nearest ESAB dealer.

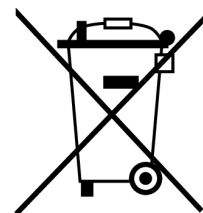

**ESAB has an assortment of welding accessories and personal protection equipment for purchase. For ordering information contact your local ESAB dealer or visit us on our website.**

## 2 INTRODUCTION

---

The **Rogue EM 180 PRO** is a self-contained single phase welding system that is capable of performing GMAW (MIG) and MMA / SMAW / Stick welding.

### 2.1 Equipment

Rogue EM 180 PRO is supplied with:

- Welding power source
- MXL 201, Euro, 3 m
- Gas hose, 4 m
- Work clamp lead set, 3 m, 16 mm<sup>2</sup>, 35-50 OKC
- Electrode holder, Handy 200A, heavy duty 50 mm OKC, 3 m
- OK Aristo Rod 12.50 0.8 mm, 1 kg
- Feed roll, 0.6/0.8 mm V
- Feed roll, 0.8/1.0 mm V
- Feed roll, 1.0/1.2 mm VK
- Instruction manual
- Safety instruction

### 3 TECHNICAL DATA

<b>Rogue EM 180</b>		
<b>Outlet voltage</b>	120 V, 1~ 50/60 Hz	230 V, 1~50/60 Hz
<b>Primary current</b>		
<b>I<sub>max</sub> GMAW - MIG</b>	20 A	23 A
<b>I<sub>max</sub> SMAW - MMA</b>	19 A	21 A
<b>I<sub>eff</sub> GMAW - MIG</b>	10 A	11.5 A
<b>I<sub>eff</sub> SMAW - MMA</b>	9.5 A	11.0 A
<b>No-load power demand</b> when in energy saving mode	20 W	
<b>Setting range</b>		
GMAW	30 A/15.5 V – 100 A/19 V	30 A/15.5 V – 180 A/23 V
SMAW	10 A/20.4 V – 80 A/23.2 V	10 A/20.4 V – 150 A/26 V
<b>Permissible load at GMAW</b>		
25% duty cycle	100 A / 19 V	180 A / 23 V
60% duty cycle	64.5 A / 17.2 V	116 A / 19.8 V
100% duty cycle	50 A / 16.5 V	90 A / 18.5 V
<b>Permissible load at SMAW</b>		
25% duty cycle	80 A / 23.2 V	150 A / 26 V
60% duty cycle	52 A / 22.1 V	97 A / 23.9 V
100% duty cycle	40 A / 21.6 V	75 A / 23 V
<b>Power factor</b> at maximum current		
GMAW	0.8	
SMAW	0.8	
<b>Efficiency</b> at maximum current		
GMAW	82.7%	
SMAW	82.7%	
<b>Open-circuit voltage U<sub>0</sub> max</b>	78 V	
<b>Operating temperature</b>	-10 to +40°C (+14 to 104°F)	
<b>Transportation temperature</b>	-20 to +55°C (-4 to +161°F)	
<b>Constant sound pressure when idling</b>	<66 db	
<b>Wire feed speed range</b>	2-16.5 m/min (75~650 in/min)	
<b>Bobbin size</b>	100 mm (4 in.) 200 mm (8 in.)	
<b>Wire diameter</b>		
GMAW	0.6 – 0.8 mm (.023–.030 in.)	
FCAW	0.8 – 0.9 mm (.030–.035 in.)	
<b>Maximum material thickness</b>		

	<b>Rogue EM 180</b>
Mild steel	24 ga - 0.5-10 mm (3/8 in.)
Aluminum	16 ga. - 1.5-10 mm (3/8 in.)
<b>Dimensions l × w × h</b>	590 × 220 × 385 mm (23.2 × 8.7 × 15.2 in.)
<b>Weight</b>	16.2 kg (35.6 lbs)
<b>Enclosure class</b>	IP23S
<b>Application class</b>	<b>S</b>

**Duty cycle**

The duty cycle refers to the time as a percentage of a ten-minute period that you can weld or cut at a certain load without overloading. The duty cycle is valid for 40 °C / 104 °F, or below.

**Enclosure class**

The **IP** code indicates the enclosure class, i.e. the degree of protection against penetration by solid objects or water.

Equipment marked **IP23S** is intended for indoor and outdoor use; however, should not be operated in precipitation.

**Application class**

The symbol **S** indicates that the power source is designed for use in areas with increased electrical hazard.

## 4 INSTALLATION

The installation must be carried out by a professional.



### CAUTION!

This product is intended for industrial use. In a domestic environment this product may cause radio interference. It is the user's responsibility to take adequate precautions.



### CAUTION!

Remove any packaging material prior to use. Do not block the air vents at the front or rear of the welding power source.

### 4.1 Location

Position the power source so that cooling air inlets and outlets are not obstructed.

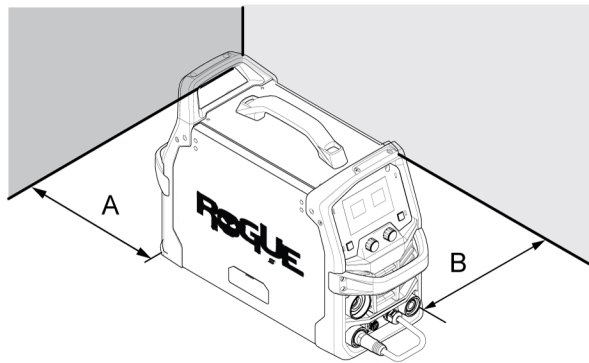

A. Minimum 8 in. (200 mm)

B. Minimum 8 in. (200 mm)

### 4.2 Lifting instructions

The power source can be lifted using any of the handles.

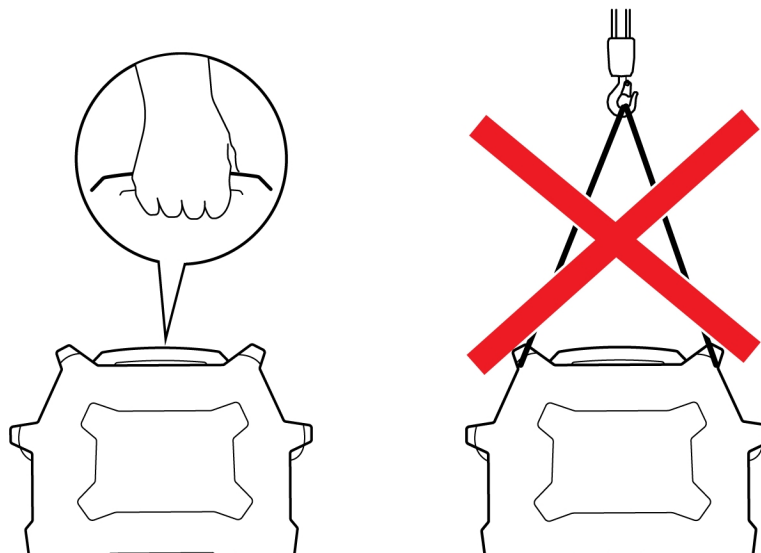

**WARNING!**

Secure the equipment - particularly if the ground is uneven or sloping.

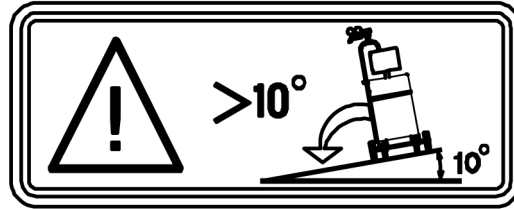

### 4.3 Mains supply

The supply voltage should be 230 V AC  $\pm 15\%$  or 120 V  $\pm 15\%$ . Too low supply voltage may cause poor welding performance. Too high welding supply voltage will cause components to overheat and possibly fail. Contact the local electric utility for information about the type of electrical service available, how proper connections should be made, and inspection required.

The welding power source must be:

- Correctly installed, if necessary, by a qualified electrician.
- Correctly earthed (electrically) in accordance with local regulations.
- Connected to the correct size power point and fuse as table below.

**CAUTION!**

Disconnect input power and secure employing 'Lock-out' / 'Tagging' procedures. Ensure input power line disconnect switch is locked (lock-out/Tagging) in the 'Open' position BEFORE removing input power fuses. Connection/Disconnect should be carried out by competent persons.

**NOTE!**

Use the welding power source in accordance with the relevant local and national regulations.

#### 1. Rating plate

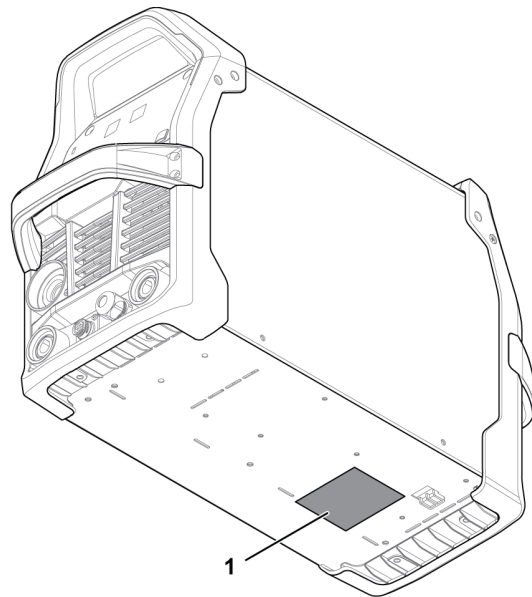

## 4.4 Recommended fuse and cable sizes



### WARNING!

An electrical shock or fire hazard is probable if the following electrical service guide recommendations are not followed. These recommendations are for a dedicated branch circuit sized for the rated output and duty cycle of the welding power source

Supply voltage	120 V AC	230 V AC
Input current at maximum output	20 A	23 A
Maximum recommended fuse* or circuit breaker rating * Time delay fuse	25 A	
Maximum recommended fuse of circuit breaker rating	32.0 A	
Minimum recommended cord size	2.5 mm <sup>2</sup> (14 AWG)	
Maximum recommended extension cord length	100 m (325 ft)	
Minimum recommended grounding conductor size	2.5 mm <sup>2</sup> (14 AWG)	

### Supply from power generators

The power source can be supplied from different types of generators. However, some generators may not provide sufficient power for the welding power source to operate correctly. Generators with Automatic Voltage Regulation (AVR) or with equivalent or better type of regulation, with rated power 7 kW, are recommended.

---

## 5 OPERATION

---

General safety regulations for handling the equipment can be found in the "SAFETY" chapter of this manual. Read it through before you start using the equipment!



**WARNING!**

Rotating parts can cause injury, take great care.



**WARNING!**

Electric shock! Do not touch the workpiece or the welding head during operation!



**WARNING!**

Assure that the side panels are closed during operation.



**WARNING!**

Tighten the bobbin locking nut in order to prevent it from sliding off the hub.



**NOTE!**

When moving the equipment use intended handle. Never pull the cables.

## 5.1 Connections

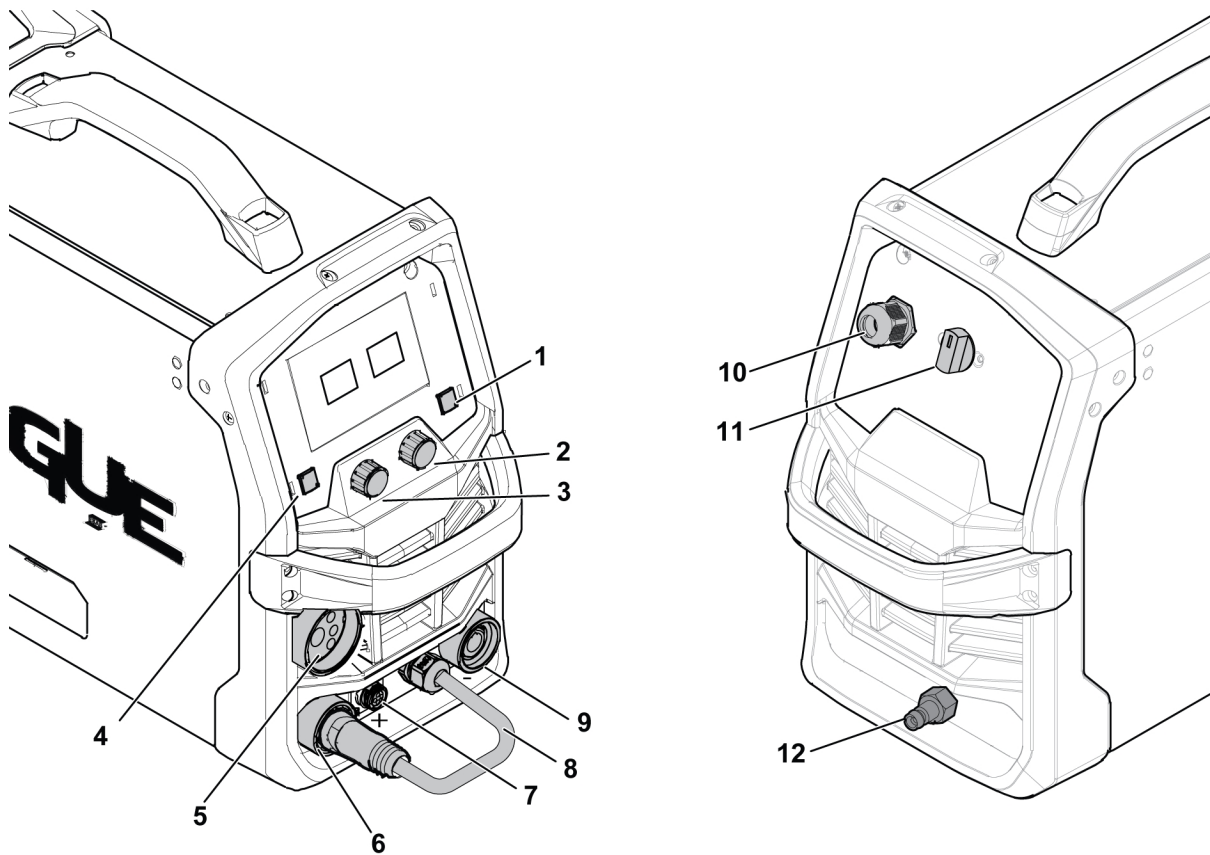

- |   |   |
|---|---|
| 1. Push button - Arc dynamics, trigger control                  | 7. Torch trigger and spool torch control receptacle |
| 2. Encoder – Adjusts Wire feed speed and selects weld variables | 8. Polarity changeover cable                        |
| 3. Encoder – Adjusts Voltage control and selects weld variables | 9. Electrode negative terminal [-]                  |
| 4. Push button selector - weld variables                        | 10. Mains supply cable                              |
| 5. GMAW torch and spool torch connection                        | 11. Mains supply switch, ON/OFF                     |
| 6. Electrode positive terminal (+)                              | 12. Gas inlet                                       |

## 5.2 Cable connection - Weld, return and polarity change over

The power source has two output studs for connecting the weld and return cables: Electrode negative [-] terminal (9) and Electrode positive [+] terminal (6), see "[Connections](#)", page 14.

The polarity changeover cable is used to select the correct polarity for the weld output. The correct polarity is determined by the wire that has been selected to complete the weld. To configure the machine to operate with electrode positive insert and secure the polarity changeover cable into the positive [+] terminal and the return lead into the negative [-] terminal. Be sure that the connections are tight. Secure the work clamp to the work piece in a clean, debris free location.



### NOTE!

Some wires it is recommended to use negative polarity such as self-shielded flux-core. See wire manufacturers recommendation.

## 5.3 Drive system diagram

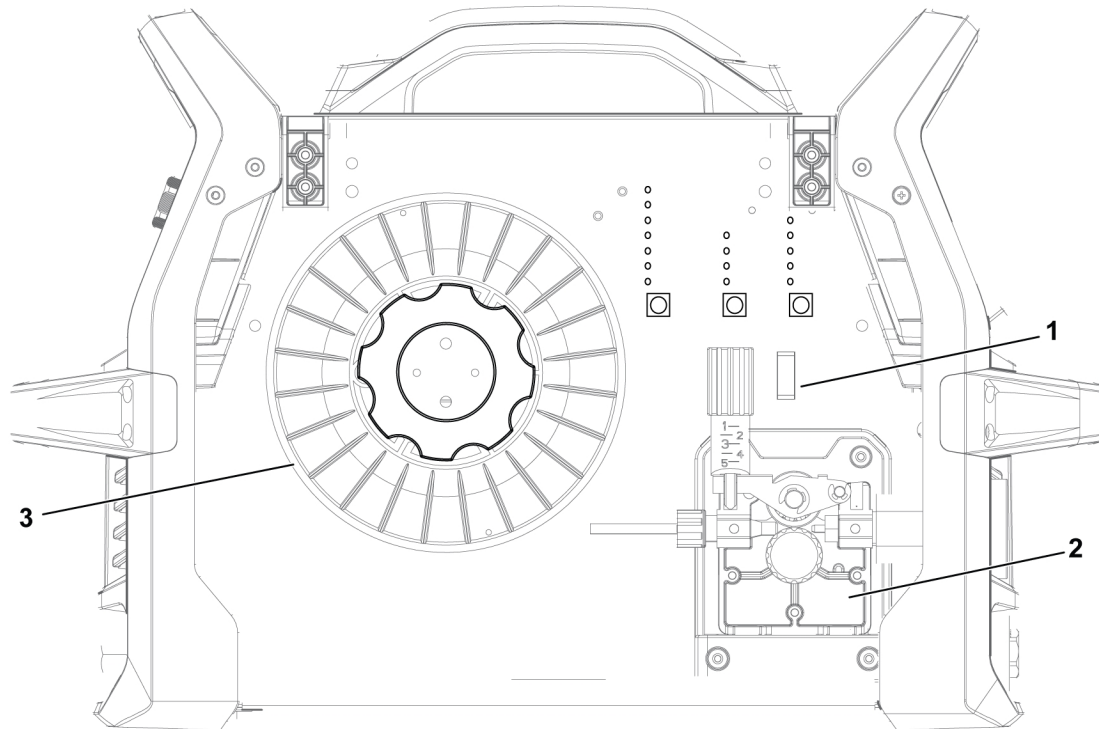

- 1. Wire inching / Gas Purge
- 2. Wire feed mechanism
- 3. Wire spool

## 5.4 Attaching MXL 201 with central adapter

- 1) Check that the wire guide liner is fitted correctly.
- 2) Insert the central plug into the mating socket on the power supply and tighten the adaptor nut firmly to secure it.
- 3) Ensure the central adapter and mating socket are connected properly by pulling on the torch coaxial cable. Movement should not be possible.

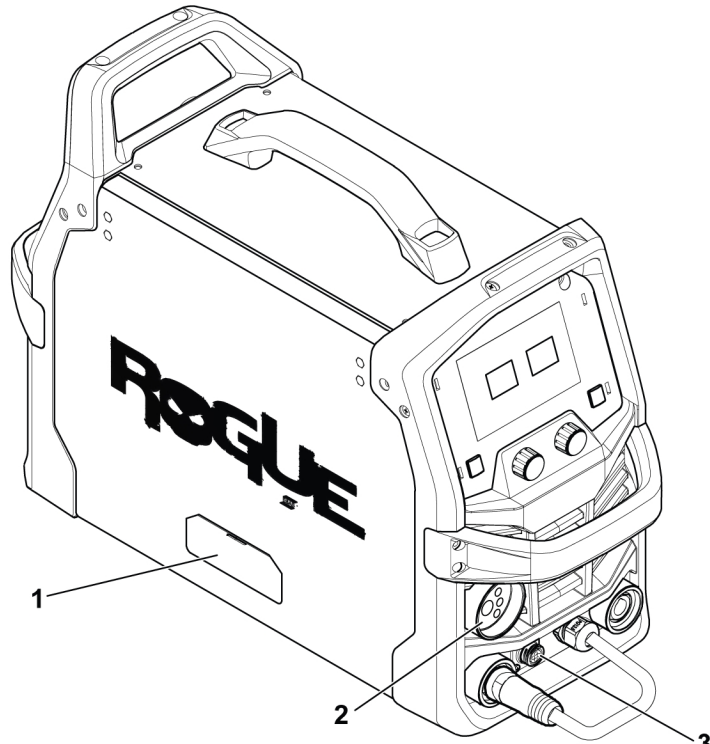

- 1. Wire Feed Compartment Door
- 2. Torch Receptacle

- 3. Remote Receptacle



**WARNING!**

The mains supply must be disconnected.

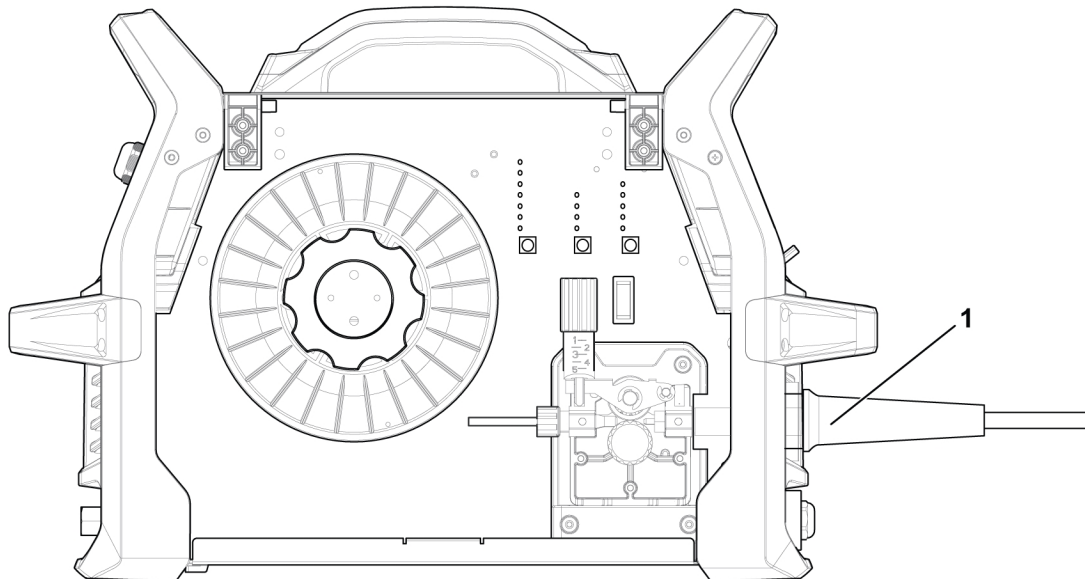

- 1. Torch receptacle

## 5.5 Inserting and replacing wire

Rogue EM 180 can be used with bobbin sizes of 100 mm (4 in.) and 200 mm (8 in.). See the TECHNICAL DATA" chapter for suitable wire dimensions for each wire type.

**WARNING!**

Do not place or point the torch near the face, hand or body as this may result in personal injury.

**WARNING!**

Risk of crushing when replacing the wire bobbin! Do **not** use safety gloves when inserting the welding wire between the feed rollers.

- 1) Open the spool side door.
- 2) Release the pressure roller arm by levering the tension screw toward you (1).
- 3) Lift the pressure roller arm up (2).
- 4) With the GMAW welding wire feeding from the bottom of the spool, pass the electrode wire through the inlet guide (3), between the rollers, through the outlet guide and into the GMAW torch. Ensure the wire is aligned with the correct groove in the drive roll.
- 5) Re-secure the pressure roller arm and wire drive tension screw and adjust the pressure if necessary.
- 6) With the GMAW torch lead reasonably straight, feed the wire through the GMAW torch by depressing the wire inch button or trigger switch.
- 7) Close the spool side door.

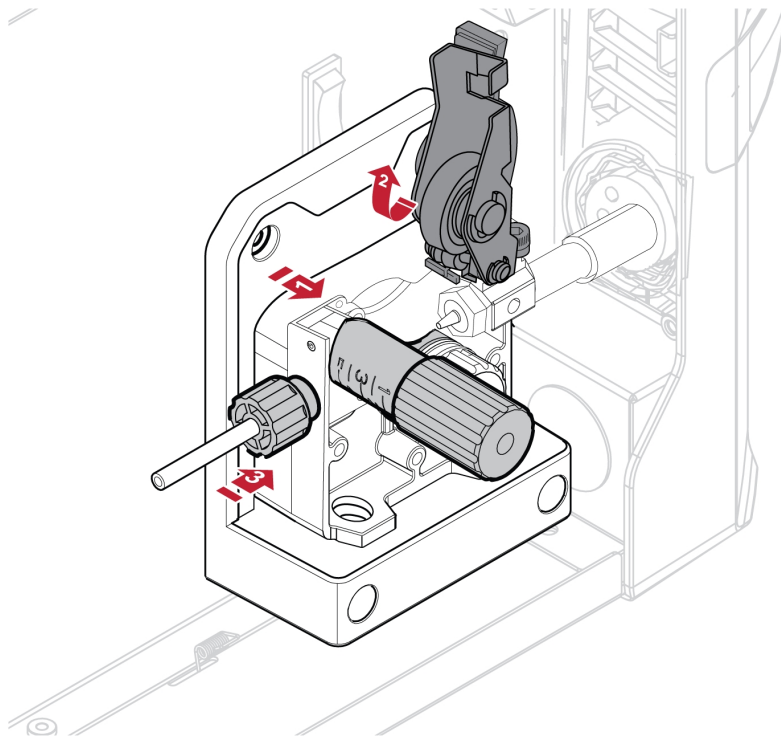

### 5.5.1 Welding with aluminium wire

To ensure the best results welding aluminum with the MXL 210, use a Teflon liner and U groove drive roll and keep the torch conduit as straight as possible.

### 5.5.2 Installing 5 kg (200 mm spool)

In order to fit a 5 kg spool (200 mm diameter), assemble parts in the sequence shown in the figure below. To install wire spool, follow the steps below.

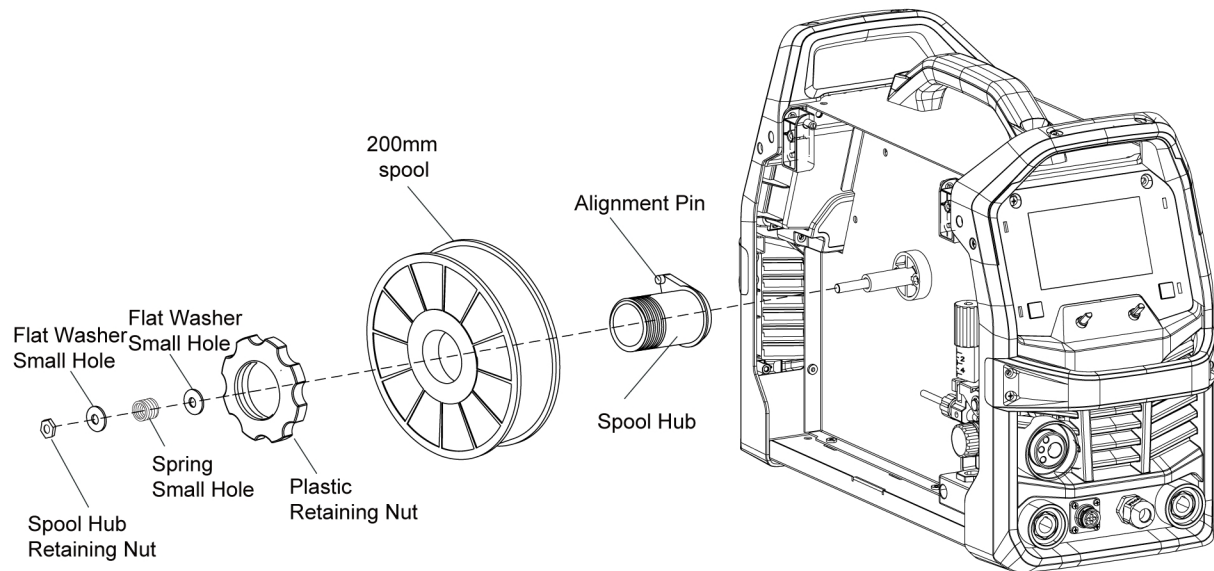

- 1) Remove plastic retaining nut.
- 2) Place wire spool onto the hub, loading it so that the wire will feed off the bottom of the spool as the spool rotates counterclockwise. Make sure to align the spool alignment pin on the hub with the mating hole in the wire spool.
- 3) Replace the plastic retaining nut until tight against wire spool.

### 5.5.3 Installing 1 kg (100 mm spool)

In order to fit a 1 kg spool (100 mm diameter), assemble parts in the sequence shown in the figure below. To install wire spool, follow the steps below.

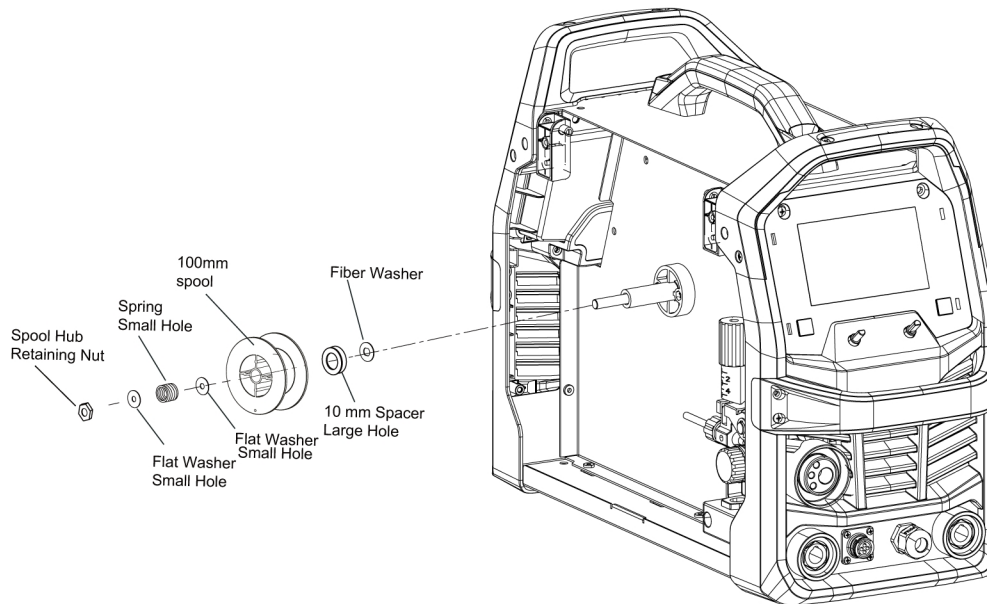

- 1) Remove plastic retaining nut.
- 2) Place wire spool onto the hub, loading it so that the wire will feed off the bottom of the spool as the spool rotates counterclockwise. Make sure to align the spool alignment pin on the hub with the mating hole in the wire spool.
- 3) Replace the plastic retaining nut until tight against wire spool.

## 5.6 Setting the wire feed pressure

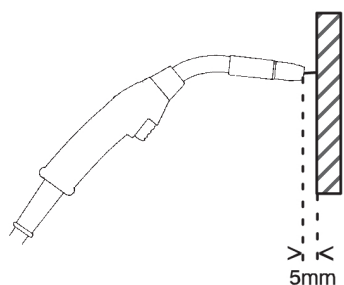

*Illustration A*

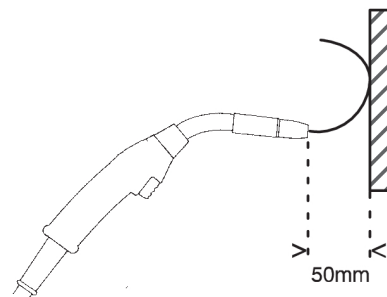

*Illustration B*

Start by making sure that the wire moves smoothly through the wire guide. Then set the pressure of the wire feeder's pressure rollers. It is important that the pressure is not too high.

To check that the feed pressure is set correctly, you can feed out the wire against an insulated object, e.g. a piece of wood.

When you hold the welding torch approximately 5 mm (0.2 in.) from the piece of wood (illustration A), the feed rollers should slip.

If you hold the welding torch approximately 50 mm (2 in.) from the piece of wood, the wire should be fed out and bend (Illustration B).

The wire reel hub incorporates a friction brake which is adjusted during manufacture for optimum braking. If it is considered necessary, adjustment can be made by turning the thumb screw inside the open end of the hub clockwise to tighten the brake. Correct adjustment will result in the wire reel

circumference continuing no further than 1/8 in.-3/16 in. (3-5 mm) after release of the trigger. The electrode wire should be slack without becoming dislodged from wire spool.

**CAUTION!**

Overtension of the brake will cause rapid wear of mechanical wire feeder parts, overheating of electrical components and possibly more incidences of contact tip burnback.

## 5.7 Changing the feed/pressure rollers

One dual groove feed roller is supplied as standard. Change the feed roller to match the filler metal wire diameter.

- 1) Open the spool side door.
- 2) Release the pressure roller arm by levering the tension screw.
- 3) Lift the pressure roller arm.
- 4) Remove the feed roll retaining screw by turning it counterclockwise.
- 5) Change the feed roll.
- 6) Tighten the feed roll retaining screw by turning it clockwise.
- 7) Secure the pressure roller arm and wire drive tension screw.
- 8) Close the spool side door.

**NOTE!**

Visual indication on the face of the drive roll indicates the diameter of the groove on the inside of the drive roll and the groove that is in use for the selected wire diameter.

**NOTE!**

Be sure not to lose the key located on the drive motor shaft. This key must be in place and aligned with the drive roll slot for proper operation.

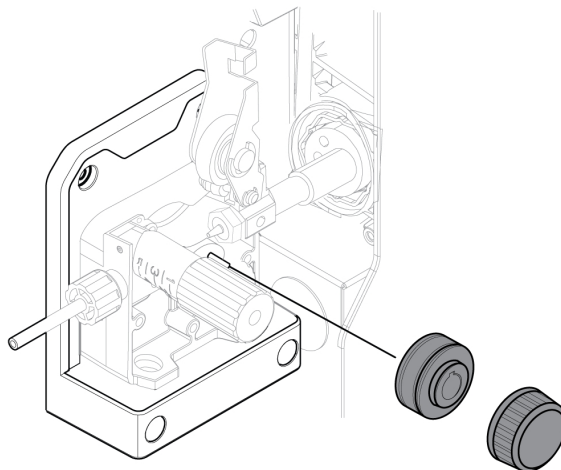
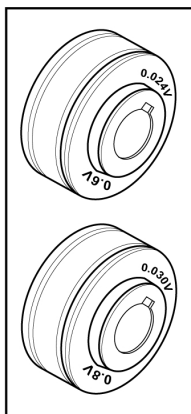

## 5.8 Shielding gas

The choice of suitable shielding gas depends on the material. Typically mild steel is welded with mixed gas (Ar + CO<sub>2</sub>) or 100% carbon dioxide (CO<sub>2</sub>). Stainless Steel can be welded with mixed gas

(Ar + CO<sub>2</sub>) or Trimix (He + Ar + CO<sub>2</sub>). Aluminum can be welded with argon gas (Ar) and silicon bronze can be welded with use pure argon gas (Ar) or (Ar + O<sub>2</sub>).

## 5.9 Duty cycle

At 25% duty cycle, the Rogue EM 180 have a welding current output of 100 A (120 V) and 180 A (230 V). A self-resetting thermostat will protect the power source if the duty cycle is exceeded.

**Example:** If the power source operates at a 25% duty cycle, it will provide the rated amperage for a maximum of 2.5 minutes out of every 10-minute period. The remaining time, 7.5 minutes, the power source must be allowed to cool down.

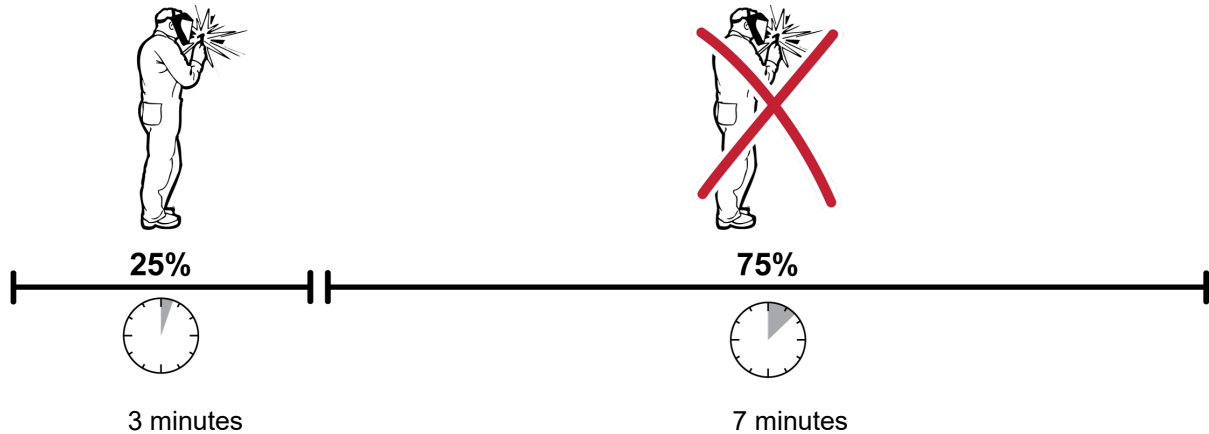

A different combination of duty cycle and welding current can be selected.

## 6 USER INTERFACE

General safety regulations for handling the equipment can be found in the "SAFETY" chapter of this manual. Read it through before you start using the equipment!

General information about operation can be found in the "OPERATION" chapter of this manual. Read it through before you start using the equipment!

### 6.1 External control panel

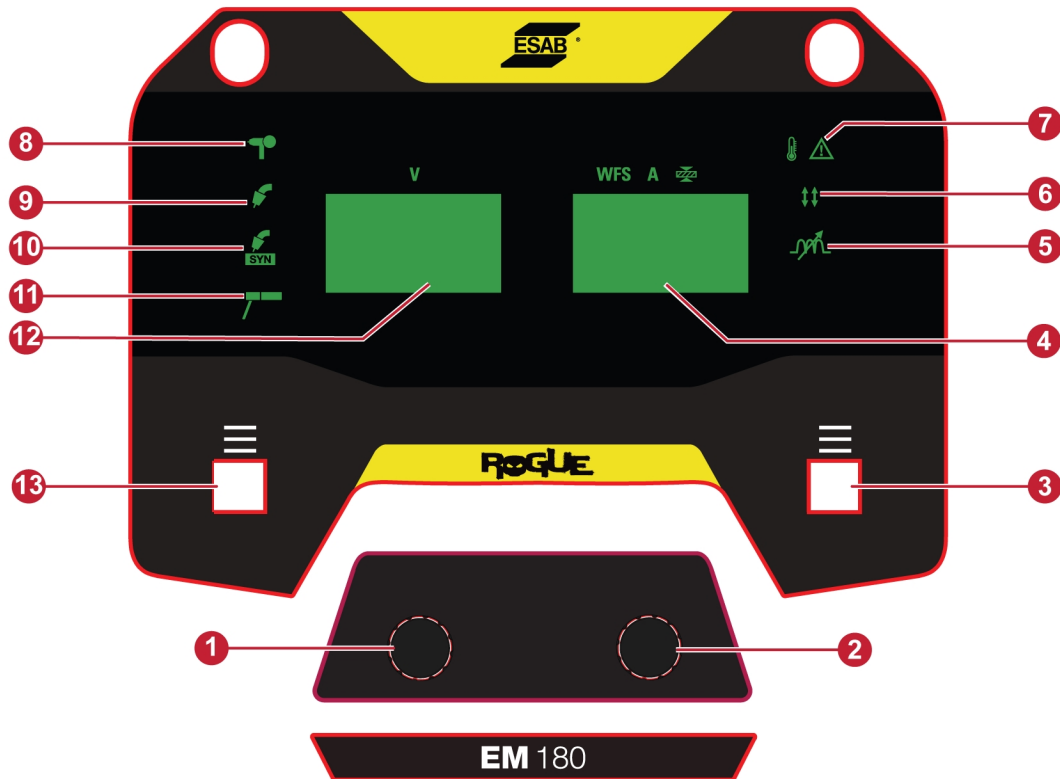

- |   |  |
|---|--|
| 1. Encoder 1 - Adjusts voltage and selects weld variables   | 8. Spool gun LED - Illuminates when the spool gun trigger leads are connected  |
| 2. Encoder 2 - Adjusts wire feed speed and selects weld variables   | 9. MIG LED - Illuminates when the process has been selected  |
| 3. Push button 2 - Selects arc dynamics and trigger mode  | 10. MIG Synergic LED - Illuminates when the process has been selected. Used in conjunction with Synergic control panel |
| 4. Right-hand display - Displays material thickness or preset wire feed speed, trigger mode, arc dynamics value, and weld variable values | 11. MMA LED - Illuminates when the process has been selected   |
| 5. Arc Dynamics LED - Illuminates when feature is selected  | 12. Left-hand display - Displays preset voltage and various weld variables   |
| 6. Trigger mode LED - Illuminates when feature is selected  | 13. Push button 1 - Selects various weld variables   |
| 7. Over temperature indication  |  |

### 6.2 Weld variables

To access Weld variables:

- Press and hold push button 1 (13) for 2 seconds.

- Use encoder 1 (1) to select the weld variable to adjust.
- Use encoder 2 (2) to adjust the value.

#### **Pre-flow (PRE)**

Pre-flow is the time during which shielding gas flows before the arc is struck. Setting range is 0.0 – 5.0s.

#### **Creep start (RIN)**

Creep start feeds the wire at a lower wire feed speed than the preset wire feed speed until it makes electrical contact with the workpiece, transitioning to the preset wire feed speed. Set a percentage of preset wire feed speed.

#### **Burnback (B-B)**

Burnback is a time delay between the time when the wire starts to break and when the power source disables the welding output.

Too short burnback time will result in a long wire stick out after completion of welding, with the risk of the wire being stuck in the solidifying weld pool.

Too long burnback time results in a shorter stick out with an increased risk of the wire burning back to the contact tip.

#### **Post-flow**

Post-flow is the time during which shielding gas flows after the arc is extinguished. The setting range is 0.0 to 10.0s.

## **6.3 Arc dynamics and trigger selection**

To access Weld variables:

- Press and hold push button 2 (3) for 2 seconds.
- Use Encoder 1 (1) to select the Trigger or Arc Dynamics.
- Use Encoder 2 (2) to adjust the value.

#### **2-stroke**

With 2-stroke, gas pre-flow starts when the welding torch trigger is pressed when the feature is active. The welding process then starts. Releasing the torch trigger stops welding entirely and starts gas post-flow (if the feature is active).

#### **4-stroke**

With 4 stroke, the gas pre-flow starts when the welding torch trigger is pressed and the wire feed starts when it is released. The welding process continues until the torch trigger is pressed again, the wire feed then stops and when the torch trigger is released, the gas post-flow starts (if the feature is active).

#### **Arc dynamics**

Used to adjust the intensity of the welding arc. Lower arc control settings make the arc softer with less weld spatter and better wetting action of the weld puddle. Higher arc control settings give a more driving arc, which can increase weld penetration. The setting range is -9 to +9.

## 6.4 Synergic control panel

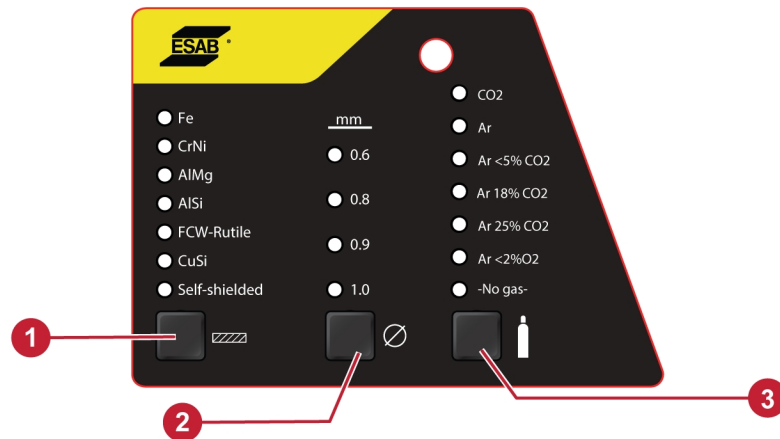

1. Material selection button
2. Wire diameter selection button
3. Gas selection button

### Material selection button

Use it to select the type of wire to be welded with for optimal weld characteristics.

### Wire diameter selection button

Use it to select the diameter of the wire installed.

### Gas selection button

Use it to select the proper gas type that is connected to the equipment on the synergic control panel.



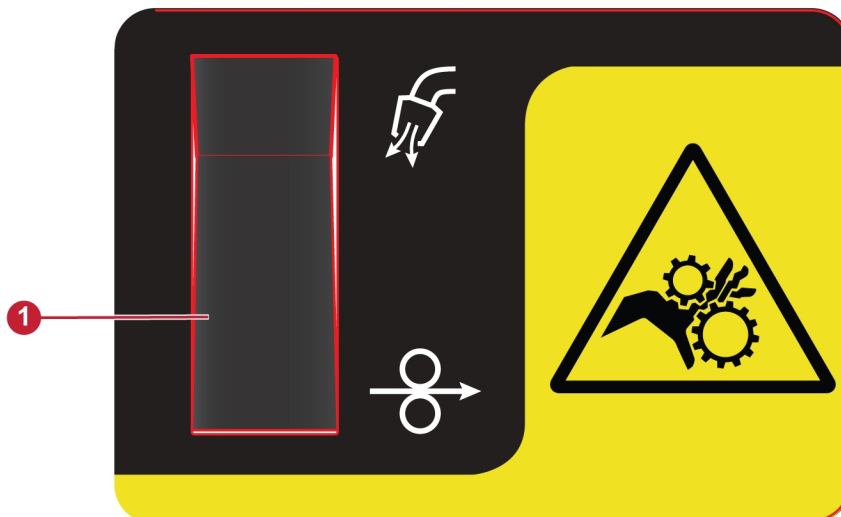

## 6.5 Wire inching and gas purge button



1. Wire inch and gas purge button

Wire inching is used to feed wire without welding voltage applied. The wire is fed as long as the button is pressed. This function is active in Synergic MIG and MIG applications only. Gas purging is used while measuring the gas flow or for flushing any air or moisture from the gas hoses before welding starts. Gas purging occurs for 15 seconds when the gas purge button is pressed or until it is pressed again. Gas purge occurs without voltage or wire feeding. This function is active in Synergic MIG and MIG applications only.

## 6.6 Icon reference guide

	MIG Manual		MIG Synergic
	MMA		Over Temperature Indicator
	2T, Trigger On/Off		4T, Trigger Hold/Lock
	Spool Gun	<b>WFS</b>	Wire Feed Speed
	Arc Dynamics		Material Thickness
<b>V</b>	Voltage	<b>A</b>	Amperage
	Gas Purging		Wire Inching
	Jobs		Gas Cylinder
	Material		Wire Diameter
<b>+/-</b>	Polarity		

## 7 MAINTENANCE

**WARNING!**

The mains supply must be disconnected during cleaning and maintenance.

**CAUTION!**

Only persons with the appropriate electrical knowledge (authorised personnel) may remove the cover of the product or carry out service, maintenance or repair work on the welding equipment.

**CAUTION!**

The product is covered by manufacturer's warranty. Any attempt to carry out repair work by non-authorised service centers or personnel will invalidate the warranty.

**NOTE!**

Regular maintenance is important for safe and reliable operation.

**NOTE!**





Perform maintenance more often during severe dusty conditions.

Before each use - make sure that:

- Product and cables are not damaged,
- The torch is clean and not damaged.

### 7.1 Routine maintenance

Maintenance schedule during normal conditions. Check equipment prior to every use.

Interval	Area to maintain	
Each use	 Visual check of regulator and pressure	 Visual check of torch consumable
Weekly	 Visually inspect the torch body and consumables	 Visually inspect the cables and leads. Replace if necessary

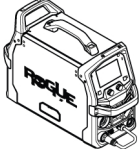
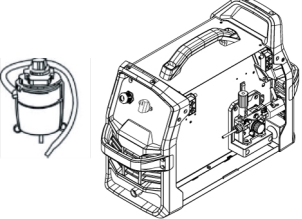
Interval	Area to maintain	
Every 3 months	 Replace all broken parts	 Clean exterior of power source
Every 6 months	 Bring the unit to an authorized service provider to remove any accumulated dirt and dust from the interior. This may need to be done more frequently under exceptionally dirty conditions.	

## 7.2 Power source and wire feeder maintenance

General practice is to perform a power source cleaning each time a wire bobbin is replaced.

**WARNING!**

Always wear safety gloves and protective eye wear during cleaning.

**Power source and wire feeder cleaning procedure:**

- 1) Disconnect the power source from the input power receptacle.
- 2) Open the spool side door and release the tension from the pressure roller by turning the tension screw (1) counterclockwise and move it outward.
- 3) Remove the torch, wire, and wire bobbin.
- 4) Use a low-pressure dry airline to clean the power source interior and power source air inlet and outlet louvers.
- 5) Inspect the wire inlet guide (4), the drive roll (3), and torch inlet (2) for wear. If any item is worn, replace immediately. See the "WEAR PARTS" appendix for ordering replacement items.
- 6) Remove and clean the feed roller (3) with a soft brush. Clean the pressure roller attached to the wire feeder mechanism with a soft brush.

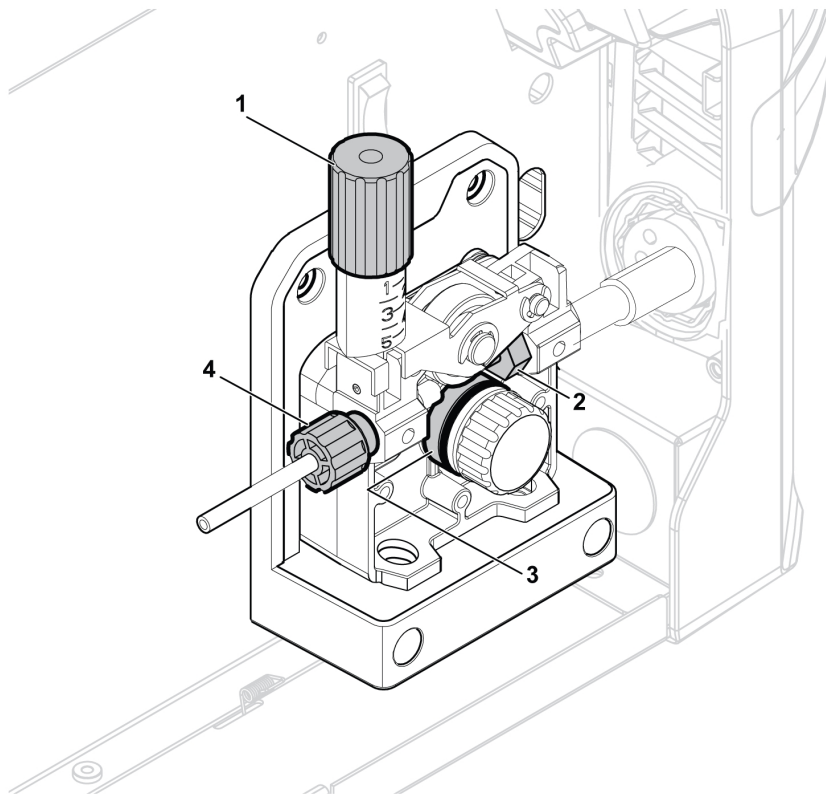

## 7.3 Torch and liner maintenance

### **Torch and liner cleaning procedure:**

- 1) Disconnect the power source from the input power receptacle.
- 2) Open the spool side door and release the tension from the pressure roller by turning the tension screw (1) counterclockwise and move it outward.
- 3) Remove the wire and the wire bobbin.
- 4) Remove the torch from the power source and remove the contact tip and nozzle.
- 5) Clean the liner by blowing low-pressure dry compressed through the end of the liner that was mounted closest to the power source.
- 6) Re-install contact tip and nozzle.

## 8 ERROR CODES

The error code is used to indicate that a fault has occurred in the equipment. Errors are indicated by the text "Err" followed by the error code number shown in the display.

### 8.1 Error code descriptions

Error codes that the user can handle are listed below. If any other error code appears, contact an authorised ESAB service technician.

<b>Error codes</b>	<b>Title</b>	<b>Display information</b>	<b>Description</b>	<b>Action</b>
002	Shorted trigger	<b>Err 002</b>	There is a fault in torch, remote control, or 8-pin connection.	Release the trigger.
205	Mains power under voltage	<b>Err 205</b>	The product has detected that the incoming mains power is outside of the product specifications.	Make sure that the mains power is within the product specification.
205	Mains power over voltage	<b>Err 205</b>	The product has detected that the incoming mains power is outside of the product specifications.	Make sure that the mains power is within the product specification.
206	Over temperature	<b>Err 206</b>	The unit has overheated and shutdown to allow the fan to cool it down. Welding can resume once the unit has cooled.	Wait until the temperature cools down.
215	Stuck Check (STICK)	<b>Err 215</b>	Stick electrode is stuck to the work piece. Clear the short and cycle power to resume welding.	Break the stuck stick electrode.
216	Over current	<b>Err 216</b>	Output amperage exceeded design maximum.	Reduce settings and resume welding.
216	Output short circuit	<b>Err 216</b>	Short circuit has been detected during output activation.	Remove short circuit condition.

## 9 TROUBLESHOOTING

Perform these checks and inspections before sending for an authorised service technician.

Type of fault	Corrective action
Porosity within the weld metal	Check gas bottle is not empty.
	Check gas regulator is not closed.
	Check gas inlet hose for leaks or blockage.
	Check that the correct gas is connected and the correct gas flow is used.
	Keep the distance between the GMAW torch nozzle and the work piece to a minimum.
	Do not work in areas with drafts, which would disburse the shielding gas, are common.
	Make sure the work piece is clean, with no oil or grease on the surface, before welding.
Wire feeding problems	Make sure the wire spool brake is adjusted correctly.
	Make sure the feed roller is correct size and not worn.
	Make sure the correct pressure is set on the feed rollers.
	Make sure the correct contact tip is used and it is not worn.
	Make sure liner is the right size and type for wire.
	Make sure the liner is not bent so that friction is caused between the liner and the wire.
GMAW (MIG) welding problems	Make sure the torch is connected to the correct polarity.
	Replace contact tip if it has arc marks in the bore causing excessive drag on the wire.
	Make sure the correct shielding gas, gas flow, voltage, welding current, travel speed and torch angle is used.
	Make sure the work lead has proper contact with the work piece.
SMAW (MMA) basic welding problems	Make sure you are using the correct polarity. The electrode holder is usually connected to the positive polarity and the work lead to the negative polarity.
No power/No arc	Check that the mains switch is turned ON.
	Check if a temperature fault is shown on display.
	Check if system breaker is tripped.
	Check that the input power, welding and return cables are correctly connected.
	Check that the correct current value is set.
	Check the input power supply fuses.
The overheating protection trips frequently	Make sure that you are not exceeding the recommended duty cycle for the weld current you are using. See section "Duty cycle" in the "OPERATION" chapter.
	Make sure that the air inlets or outlets are not clogged.

## 10 ORDERING SPARE PARTS

---



**CAUTION!**

Repair and electrical work should be performed by an authorised ESAB service technician.  
Use only ESAB original spare and wear parts.

The Rogue EM 180 is designed and tested in accordance with the international standards **IEC/EN 60974-1** and **IEC/EN 60974-1 Class A**. On completion of service or repair work, it is the responsibility of the person(s) performing the work to ensure that the product still complies with the requirements of the above standards.

Spare parts and wear parts can be ordered through your nearest ESAB dealer, see [esab.com](http://esab.com). When ordering, please state product type, serial number, designation and spare part number in accordance with the spare parts list. This facilitates dispatch and ensures correct delivery.

The spare parts list is published in a separate document that can be downloaded from the Internet:  
[www.esab.com](http://www.esab.com)

# APPENDIX

## WIRING DIAGRAM

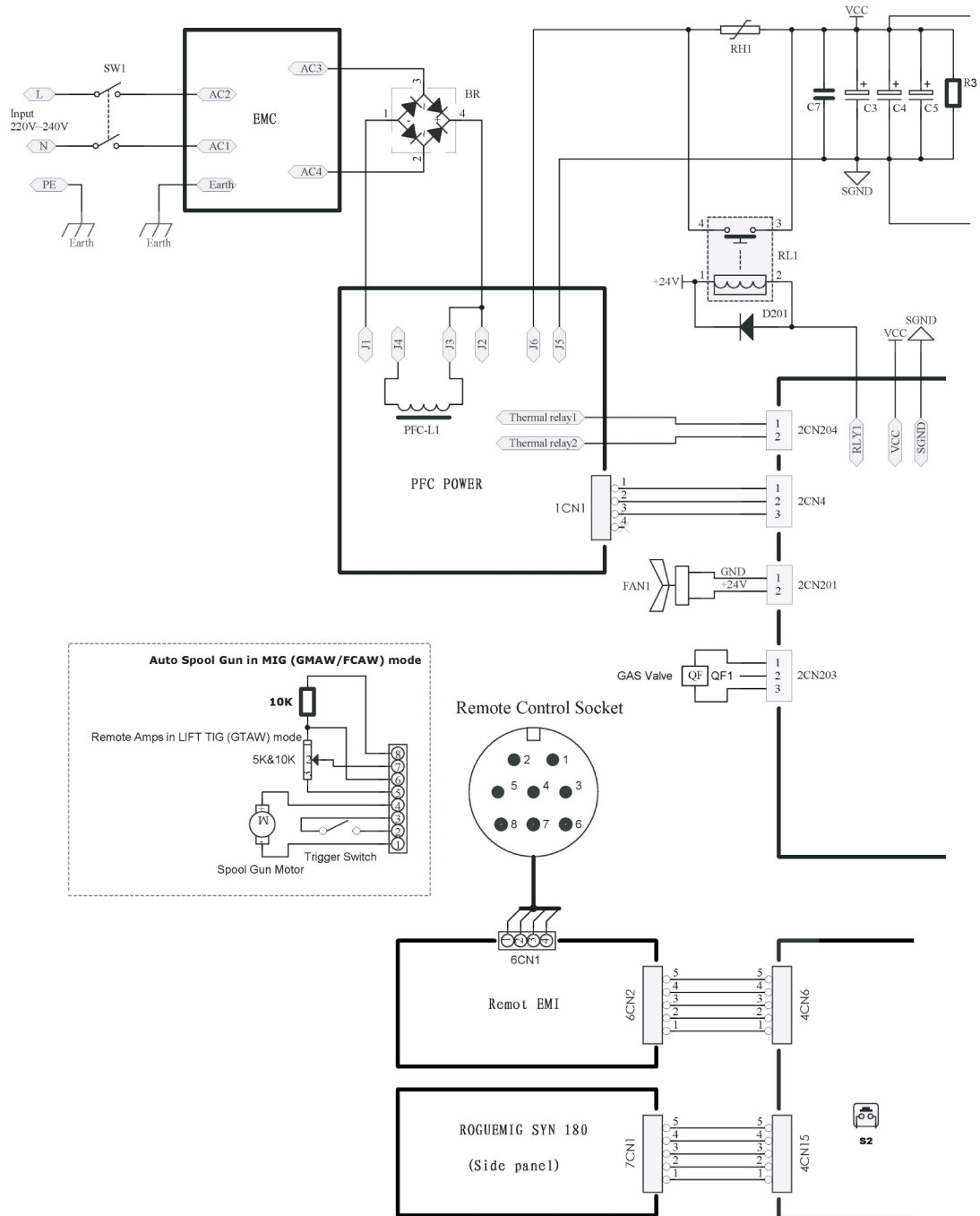

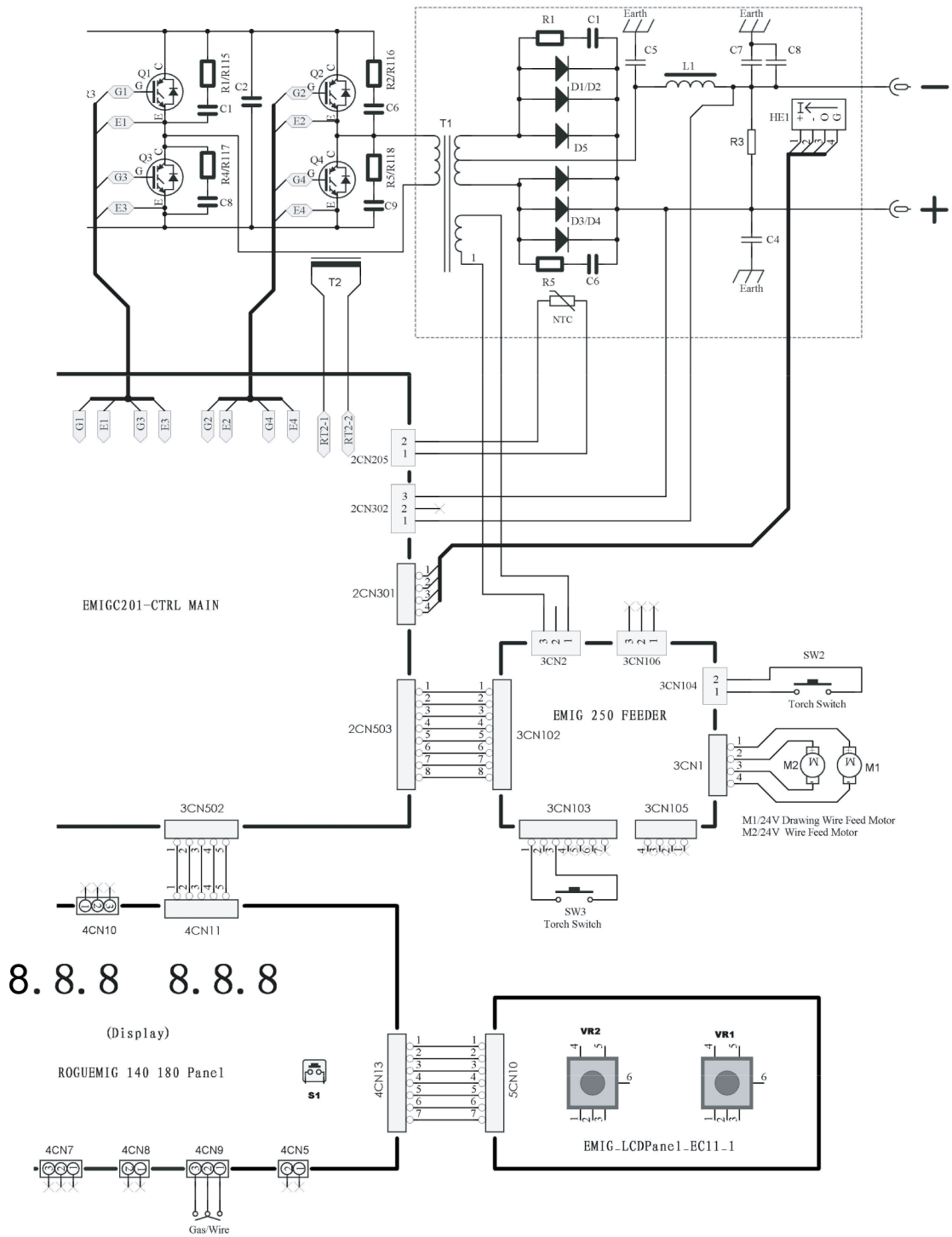

## ORDERING NUMBERS

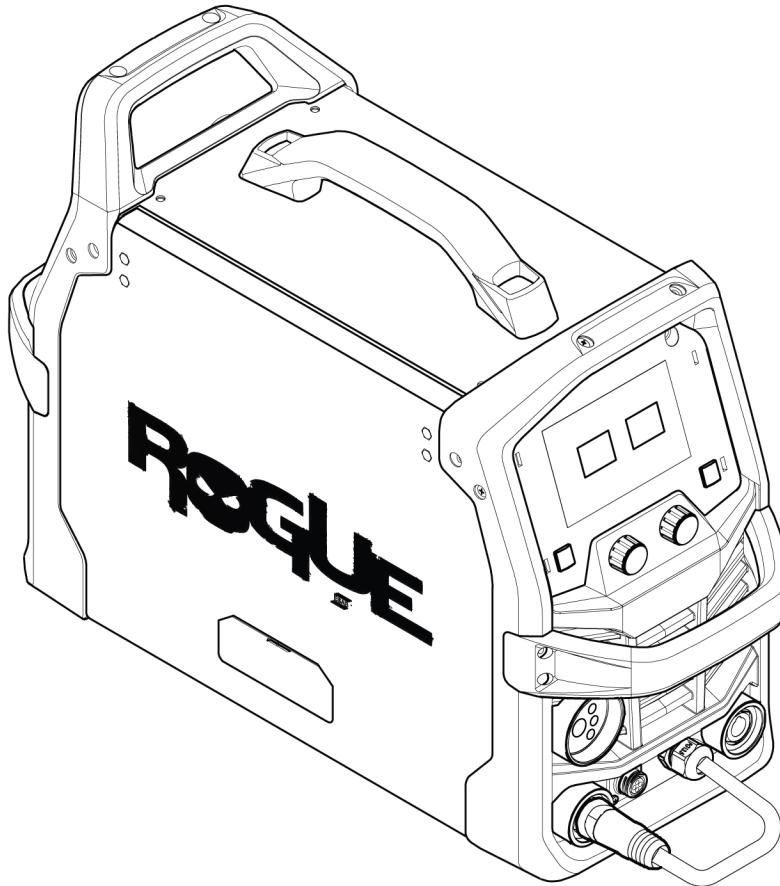

Ordering number	Denomination	Type	Notes
0700 301 091	Power source with wire feeder	Rogue EM 180	EU

Technical documentation is available on the Internet at: [www.esab.com](http://www.esab.com)

## WEAR PARTS

Ordering number	Denomination	Wire dimensions
	<b>Drive rolls</b>	
0367 556 001	Feed Roller for V	0.6 and 0.8 mm
0367 556 002	Feedroll V groove	0.8/1.0 mm
0367 556 003	Feed Roller V groove	1.0 and 1.2 mm
0367 556 004	Feedroll U groove	1.0/1.2 mm
0349 312 497	Drive Roll, V Groove	0.9/1.2 mm
0464 752 697	Feed Roll VK	0.8 /1.0 mm
0558 102 928	Guide, Inlet, Wire	
0558 102 929	Guide, Outlet, Wire	
0558 102 930	Key, Shaft, Motor, Drive	

## ACCESSORIES

0460 330 880	<b>Trolley</b> , 2-wheel with cylinder support
0700 025 220	<b>MXL 201</b> , Euro connection, 3 m (10 ft)
0700 025 221	<b>MXL 201</b> , Euro connection, 4 m (13 ft)
0349 312 105	<b>Gas hose</b> , 4.5 m (15 ft)
0700 006 901	<b>Work clamp leadset</b> , 3 m (10 ft), 16 mm <sup>2</sup> , 35-50 OKC
0700 006 900	<b>Electrode holder leadset</b> , 3 m (10 ft), 16 mm <sup>2</sup> , 35-50 OKC
0700 500 084	<b>MMA 4</b> , Remote control, 10 m (33 ft)
W4014450	<b>TIG foot control</b> , 4.5 m (15 ft), 8-pin connector
0700 026 630	<b>SR-17V</b> , 4 m, gas cooled, OKC 50, Rmt.8, gas hose 3.8 m, 5/8-18
0700 026 631	<b>SR-17V</b> , 8 m, gas cooled, OKC 50, Rmt.8, gas hose 3.8 m, 5/8-18



# A WORLD OF PRODUCTS AND SOLUTIONS.



For contact information visit [esab.com](http://esab.com)

ESAB AB, Lindholmsallén 9, Box 8004, 402 77 Gothenburg, Sweden, Phone +46 (0) 31 50 90 00

[manuals.esab.com](http://manuals.esab.com)

